

DIESEL EXHAUST FLUID PUMP MOTOR ASSEMBLY

REPLACEMENT GUIDE

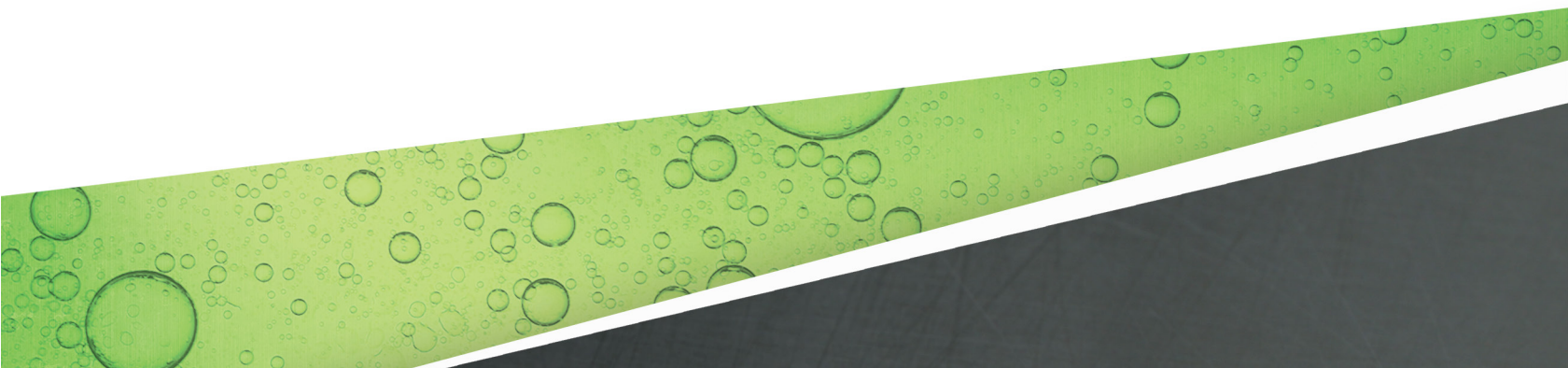

The information in this publication is provided for reference only. While every effort has been made to ensure the reliability and accuracy of the information contained in this manual at the time of printing, we recommend that you refer to “franklinfueling.com” for the most current version of this manual. All product specifications, as well as the information contained in this publication, are subject to change without notice. Franklin Fueling Systems does not assume responsibility and expressly disclaims liability for loss, damage, or expense arising out of, or in any way connected with, installation, operation, use, or maintenance by using this manual. Franklin Fueling Systems assumes no responsibility for any infringement of patents or other rights of third parties that may result from use of this manual or the products. We make no warranty of any kind with regard to this material, including, but not limited to, the implied warranties of merchantability and fitness for a particular purpose.

Copyright © 2021 Franklin Fueling Systems, LLC, Madison, WI 53718. All world rights reserved. No part of this publication may be stored in a retrieval system, transmitted, or reproduced in any way, including, but not limited to, photocopy, photograph, magnetic, or other record, without the prior written permission of Franklin Fueling Systems.

For technical assistance, please contact:

franklinfueling.com

3760 Marsh Rd. • Madison, WI 53718 • USA

Tel: USA & Canada +1 800 225 9787 • Fax: +1 608 838 6433

Tel: UK +44 (0) 1473 243300 • Tel: Mex 001 800 738 7610

Tel: DE +49 6571 105 380 • Tel: CH +86 10 8565 4566

403395001 r5

Contents

- Introduction1
- Conventions used in this manual1
- Operating precautions2
- Questions and concerns3
- Replacing the DEF-PMA5
- DEF STP Troubleshooting Checklist9
- 60 Hz Wiring Diagrams14
- 50 Hz Wiring Diagrams15

Intentionally Blank

Introduction

Diesel Exhaust Fluid (DEF) is a non-flammable, non-combustible liquid with a specific gravity of 1.09 at 20° C (68° F) and is made according to ISO 22241-1 specifications. It is composed of 32.5% urea and distilled or deionized water. DEF is used in diesel vehicles that are equipped with Selective Catalytic Reduction (SCR) emission control. DEF freezes at -11° C (12° F) and can be impaired by prolonged storage above 25° C (77° F). DEF systems require compatible materials to prevent product contamination / degradation and unintended release.

All models of this Diesel Exhaust Fluid-Pump Motor Assembly (DEF-PMA) are intended for use with DEF only. All models are suitable for vertical installation where the pump motor is suspended off the bottom of the storage tank by the discharge piping. All models are rated for continuous operation with motor cooling provided by product flow and protected from dry running. All models require a Bypass Relief Valve with a cracking pressure of 30-40 psi (2.1 - 2.8 bar) and capable of 4 gpm (15 lpm) minimum flow at the discharge. All models require a Non-Return Check Valve with a maximum cracking pressure of 3 psi (0.2 bar) between the product piping and the Bypass Relief Valve. Three Phase models require overload protection be incorporated within the motor starter, whereas Single Phase models have thermal overload protection built into the motor.

Conventions used in this manual

This manual includes safety precautions and other important information presented in the following format:

NOTE: This provides helpful supplementary information.

IMPORTANT: This provides instructions to avoid damaging hardware or a potential hazard to the environment, for example: fuel leakage from equipment that could harm the environment.

⚠ CAUTION: This indicates a potentially hazardous situation that could result in minor or moderate injury if not avoided. This may also be used to alert against unsafe practices.

⚠ WARNING: This indicates a potentially hazardous situation that could result in severe injury or death if not avoided.

⚠ DANGER: This indicates an imminently hazardous situation that will result in death if not avoided.

Operating precautions

Franklin Fueling Systems (FFS) equipment is designed to be installed in areas where volatile liquids such as gasoline and diesel fuel are present. Working in such a hazardous environment presents a risk of severe injury or death if you do not follow standard industry practices and the instructions in this manual. Before you work with or install the equipment this manual pertains to, or any other related equipment, read this entire manual, particularly the following:

⚠ CAUTION: Do not modify the DEF Pump Motor Assembly (DEF-PMA). Modifying or altering the DEF-PMA in any way defeats the rigorous quality control tests performed during assembly and could result in dangerous safety issues.

⚠ WARNING: Follow all codes that govern how you install and service this product and the entire system. Always lock out and tag electrical circuit breakers while installing or servicing this equipment and related equipment. A potentially lethal electrical shock hazard and the possibility of an explosion or fire from a spark can result if the electrical circuit breakers are accidentally turned on while you are installing or servicing this product. Refer to this manual (and documentation for related equipment) for complete installation and safety information.

⚠ WARNING: Before you enter a containment sump, check for the presence of hydrocarbon vapors. Inhaling these vapors can make you dizzy or unconscious, and if ignited, they can explode and cause serious injury or death. Containment sumps are designed to trap hazardous liquid spills and prevent environmental contamination, so they can accumulate dangerous amounts of hydrocarbon vapors. Check the atmosphere in the sump regularly while you are working in it. If vapors reach unsafe levels, exit the sump and ventilate it with fresh air before you resume working. Always have another person standing by for assistance.

⚠ WARNING: Follow all federal, state, and local laws governing the installation of this product and its associated systems. When no other regulations apply, follow NFPA codes 30A and 70 from the National Fire Protection Association. Failure to follow these codes could result in severe injury, death, serious property damage, and/or environmental contamination. Do not smoke while working on or near this equipment, and use only non-sparking tools.

⚠ WARNING: The piping and storage tank must be installed using standard industry practices, including, but not limited to:

- *Recommended Practices for Installation of Underground Storage Systems*, The Petroleum Equipment Institute, PEI/RP100 (latest edition).
- *Recommended Practices for Installation of Aboveground Storage Systems*, The Petroleum Equipment Institute, PEI/RP200 (latest edition).
- *Recommended Practices for the Storage and Dispensing of Diesel Exhaust Fluid (DEF)*, The Petroleum Equipment Institute, PEI/RP1100 (latest edition).

⚠ WARNING: Always secure the work area from moving vehicles. The equipment in this manual is usually mounted underground, so reduced visibility puts service personnel working on it in danger from moving vehicles that enter the work area. To help prevent this safety hazard, secure the area by using a service truck (or some other vehicle) to block access to the work area.

⚠ WARNING: Make sure you check the installation location for potential ignition sources such as radio waves, ionizing radiation, and ultrasound sonic waves. If you identify any potential ignition sources, you must make sure safety measure are implemented.

Questions and concerns

In case of emergency, follow the procedures established by your facility. If you have questions or concerns about safety or need assistance, use the information below to contact Franklin Fueling Systems:

Web: franklinfueling.com

Telephone:

USA and Canada: +1.608.838.8786, +1.800.225.9787

USA Technical Support: 1.800.984.6266

UK: +44 (0) 1473.243300

Mexico: 001.800.738.7610

France: +33 (0) 1.69.21.41.41

China: +86.10.8565.4566

Intentionally Blank

Replacing the DEF-PMA

1. Disconnect the power to the DEF-PMA at the electrical supply box.
2. Tag and lock out the electrical circuit breakers.

IMPORTANT: Power supply wiring for single-phase units may have a capacitor. If this is the case, make sure the capacitor is safely discharged before you disconnect the power supply wiring.

3. Disconnect the product discharge piping and power supply wiring.

IMPORTANT: Never lift or suspend the DEF Pump Assembly extractable by the power cable.

4. Remove the DEF Pump Assembly extractable from the storage tank and carefully lay it on a flat, open surface so you can replace the pump motor.
5. Disconnect the power cable from DEF Pump Assembly extractable in order to remove the PMA.
6. Remove the existing DEF-PMA from the product piping.
7. Make sure DEF Pump Assembly extractable has a Non-Return Check Valve and Bypass Relief Valve as specified in the "Introduction." (See Figure 1.)

IMPORTANT: Make sure the Non-Return Check Valve is properly oriented. If it is not, the DEF-PMA will not produce flow.

IMPORTANT: A Bypass Relief Valve must be installed to provide flow for cooling the unit. Running the DEF-PMA without product to properly cool the unit can cause irreparable damage.

8. Unpack the DEF-PMA and verify that the specifications match the installation.

NOTE: NOTE: DEF-PMA specifications are marked on the outer shell of the pump motor assembly.

IMPORTANT: Measure and compare the pump motor lengths. Make sure the DEF Assembly does not touch the bottom of the tank. The DEF-PMA will typically be suspended about 76 mm (3 inches) off the bottom of the storage tank.

Model Number	Discharge Outlet	Outside Diameter	Inlet-to-Outlet Length
DEF-PMA150A	2 in NPT Female	5.1 in (130 mm)	18.7 in (474 mm)
DEF-PMA150B	2 in BSPT Female	5.1 in (130 mm)	19.8 in (504 mm)
DEF-PMA150C	2 in BSPT Female	5.1 in (130 mm)	19.8 in (504 mm)
DEF-PMA150D	2 in NPT Female	5.1 in (130 mm)	18.7 in (474 mm)

NOTE: Do not use PTFE thread seal pipe tape. Use only DEF-compatible materials to prevent product contamination and/or unintended release.

NOTE: If the stainless tee with an access plug for the pressure gauge is connected at the access point to the tank, FFS strongly recommends installing the tee with the pressure gauge port for future troubleshooting.

9. Apply DEF compatible thread sealant to the product piping and thread on the DEF-PMA.

NOTE: To help prevent damage to the power cable, do not over-tighten the product piping while you thread it into the DEF-PMA or the discharge port may be damaged.

10. Fasten the power cable to the DEF Pump Assembly product piping to help prevent it from being damaged when you install or extract it. (See Figure 1.)

NOTE: Do not fasten the power cable too tightly. Allow enough freedom to prevent it from stretching or being cut.

11. Make sure you're using the correct capacitor for the DEF-PMA. (Three-phase models do not use a run/start capacitor. See Figures 2-5 for details.)

Model Number	Electrical Specifications	Capacitor	Voltage Rating
DEF-PMA150A	Single-phase, 60 Hz, 208–240 VAC	25 μ F	370 V (Minimum)
DEF-PMA150B	Single-phase, 50 Hz, 200–250 VAC	30 μ F	440 V (Minimum)
DEF-PMA150C	Three-phase, 50 Hz, 380–415 VAC	None	None
DEF-PMA150D	Three-phase, 60 Hz, 208–230 VAC	None	None

NOTE: FFS recommends including a bleed down resistor with the capacitor and housing the capacitor at the DEF Pump Assembly turbine sump in a liquid-tight junction box. If the capacitor is not housed in the DEF PMA turbine sump, make sure the wiring is the proper size for the length of the run, and maintain the wire color codes with the DEF-PMA to help ensure proper field wiring connections.

NOTE: Damage to the jacket of the DEF-PMA power cable can cause irreparable damage.

12. Lower the DEF Pump Assembly extractable back into the storage tank. Make sure you do not damage any components of the assembly, including the power cable or the DEF-PMA housing.

13. Secure the DEF Pump Assembly extractable in place and reconnect the product discharge.

14. Attach the DEF-PMA power cable to the supply power wiring. (See Figures 2-5.)

NOTE: Make sure all wiring is in accordance with the National Electrical Code (NEC) and any other applicable local, state, or federal regulations.

NOTE: Verify that the DEF pump controllers are wired and set correctly. (Refer to figures 2-5 and the following tables.) Running the DEF-PMA without proper overload protection can cause irreparable damage.

NOTE: Single phase STP-SCI and three phase STP-SCIII/SCIIIC Smart Controllers are not approved for use with the DEF-PMA. Guardian Controllers with 3.8 or higher firmware and DEF mode selected can operate FFS DEF-PMA models only.

Model Number	Electrical Specifications	Rated Current	Locked Rotor Current
DEF-PMA150A	Single-phase, 60 Hz, 208-240 VAC	7.9 Amps	35 Amps
DEF-PMA150B	Single-phase, 50 Hz, 200-250 VAC	6.9 Amps	32 Amps
DEF-PMA150C	Three-phase, 50 Hz, 380-415 VAC	2.6 Amps	19 Amps
DEF-PMA150D	Three-phase, 60 Hz, 208-230 VAC	5.0 Amps	38 Amps

Model Number	Lead-to-Lead Resistance (including Power Cable)		
	White/Gray - Black	Brown/Red - Black	Brown/Red - White/Gray
DEF-PMA150A	1.7–2.5 Ohms	4.6–5.4 Ohms	6.3–7.1 Ohms
DEF-PMA150B	2.5–3.3 Ohms	5.6–6.4 Ohms	8.1–8.9 Ohms
DEF-PMA150C	14.2–15.0 Ohms	14.2–15.0 Ohms	14.2–15.0 Ohms
DEF-PMA150D	2.9–3.7 Ohms	2.9–3.7 Ohms	2.9–3.7 Ohms

NOTE: Size and length of field wiring from the pump controller to the DEF-PMA can affect lead-to-lead resistance readings. If readings do not match the above table, lead-to-lead readings should be taken again at the DEF PMA power cord to confirm wiring or isolate an issue.

NOTE: If the lead-to-lead readings are not correct, before you connect power to the DEF-PMA, check the lead-to-ground readings to make sure the DEF-PMA wiring is not shorted to ground.

15. Connect the power to the DEF Pump Assembly at the electrical supply box.
16. Turn on the power to the DEF Pump Assembly and check the installation for leaks. If there are any, disconnect and lockout the power, and fix the leak(s) before proceeding.

NOTE: Do not start the DEF-PMA unless it is completely submerged in fluid. Running the DEF-PMA without product to properly cool the unit can cause irreparable damage.

NOTE: Recommend a minimum of 24" (610mm) of diesel exhaust fluid to prime a new DEF-PMA.

17. Test for proper operation by dispensing product into a calibration can. If the pressure decreases to below 24 psi (1.65 bar) with one nozzle operating, the DEF-PMA is probably running in reverse rotation.

NOTE: For three-phase models, disconnect and lockout the power, and then change the position of the two motor leads to verify rotation before proceeding. The wire position with the highest deadhead pressure is the correct rotation.

NOTE: For single-phase models, disconnect and lockout the power, and then change the position of the two motor leads across the capacitor to verify rotation before proceeding. The wire position with the highest deadhead pressure is the correct rotation.

NOTE: Running the DEF-PMA in reverse rotation significantly reduces wide open flow performance and can lead to irreparable damage. Running a single phase DEF-PMA in reverse rotation can also cause the thermal overload to activate, which inhibits motor operation until it cools properly.

18. If operation doesn't improve, or if you have any other problems or concerns, call FFS Technical Support for assistance.

NOTE: If the the DEF-PMA does not turn off when the DEF dispenser switch is turned off, or the DEF-PMA turns on without the DEF dispenser switch turned on, there may be an electrical problem in the dispenser or other wiring. Immediately consult a qualified electrician because continuous operation of the DEF-PMA can lead to irreparable damage.

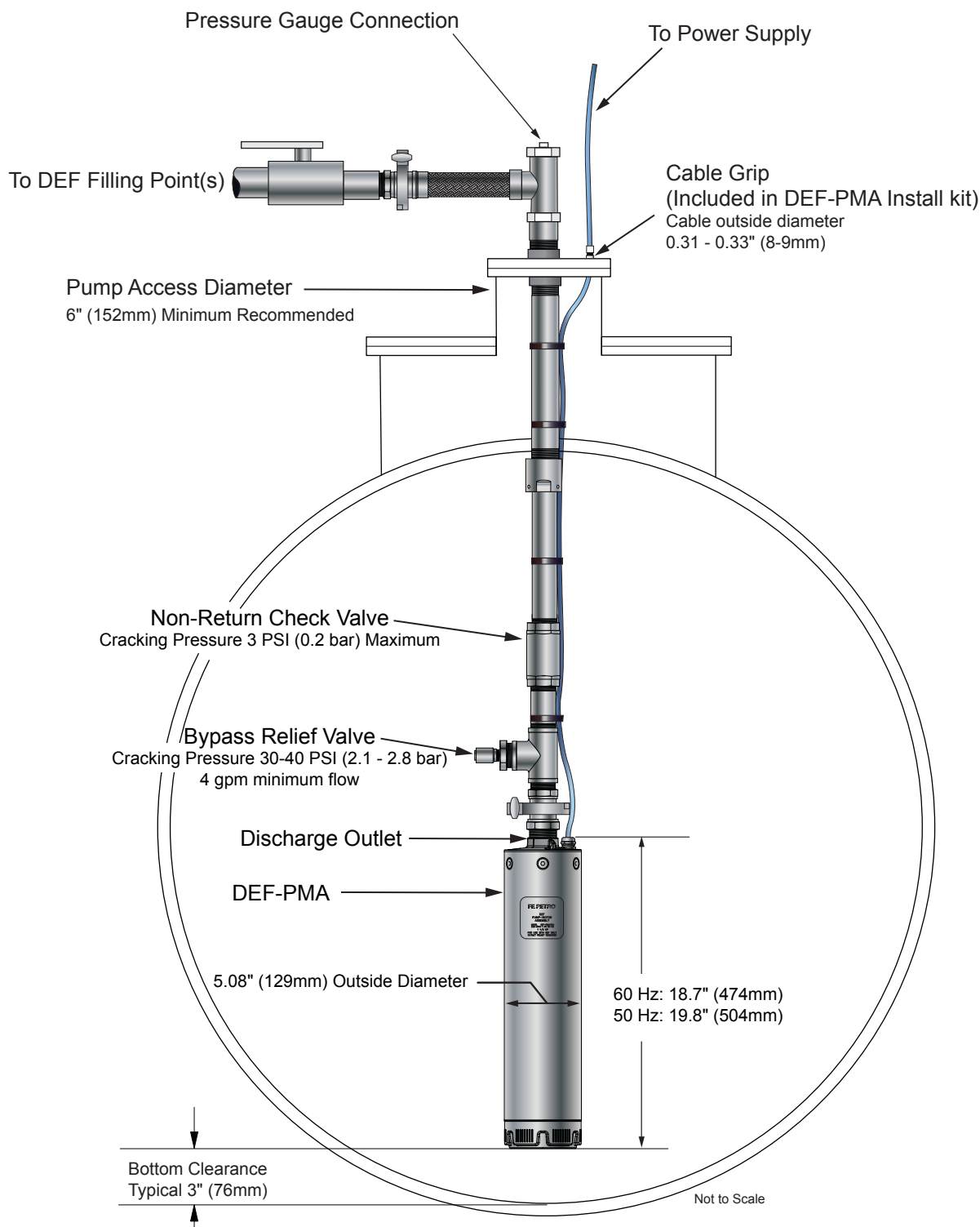

Figure 1: Typical DEF-PMA Installation

DEF STP Troubleshooting Checklist

Date of Service Call:

Site Location:

Service Contractor
Contact Information:

1. Identify Current State of DEF (check one)

- Breaker tripping.
- Humming, but not running.
- Running, but no pressure.
- Verify DEF product level.

Notes:

2. Identify DEF Configuration

ATG Integration:

Franklin Fueling Systems EVO™ Series

Veeder Root TLS-450

Manifolded Operation:

Single DEF STP

Multiple DEF STP (2 DEF Tanks)

Selector Switches :

Is a third party switch used for alternating multiple DEF STP's?

Yes

No

3. Check Voltage at Pump Controller

YES

N/A

208-230 Volt incoming and out-going.

Date completed:

Check leg-to-leg at pump controller
input terminals with DEF PMA off.

Date completed:

With DEF PMA hook energized,
check leg-to-leg at pump controller
output terminals.

Date completed:

NOTE: Single Phase model STP-SCI and Three Phase model STP-SCIII Smart Controllers are not approved for use with DEF PMAs.

NOTE: Single Phase DEF PMAs incorporate a thermal overload in the motor windings, but Three Phase DEF PMAs require properly set overload protection as part of the pump controller.

4. Identify Pump as Single or Three Phase

YES N/A

If DEF-PMA150A, check wiring from pump controller output to run/start capacitor.

Date completed:

Verify capacitor rating (25 microfarad, 370 Volt).

Date completed:

If DEF-PMA150D, check pump controller overload setting (about 9 amps).

Date completed:

DEF-PMA150A Single-Phase Wiring

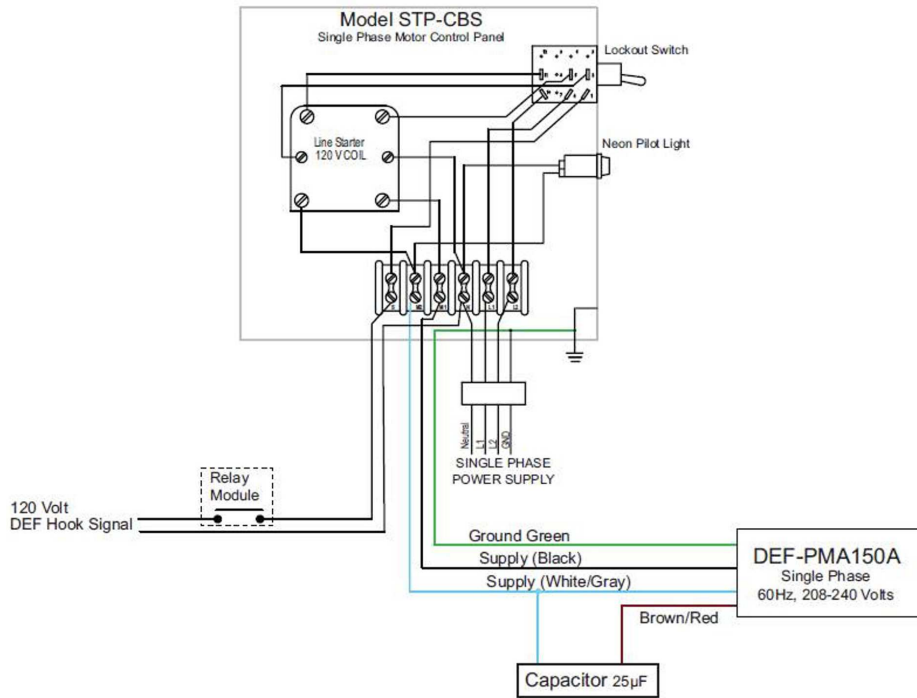

DEF-PMA150D Three-Phase Wiring

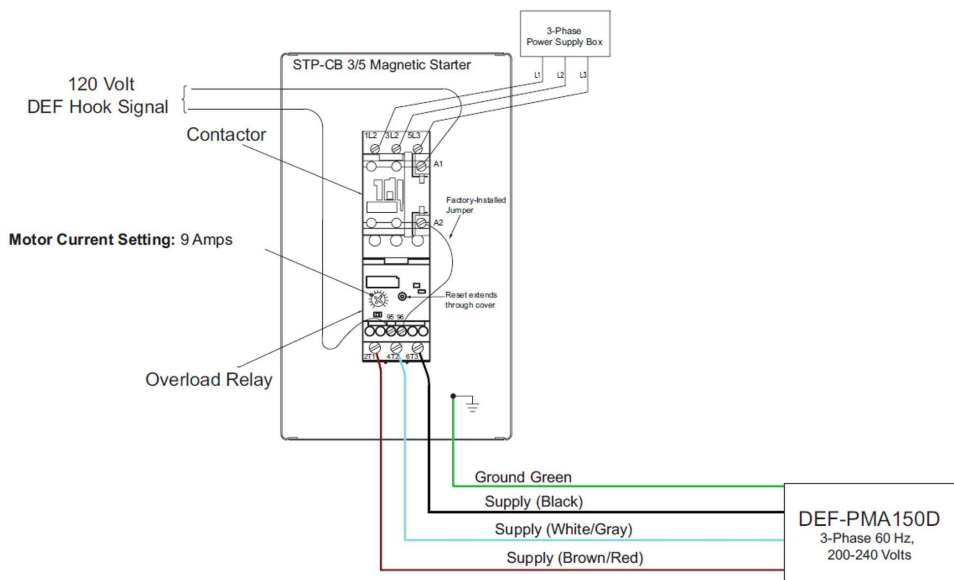

5. Check Continuity of DEF PMA Wiring

YES N/A

Verify DEF PMA Lead-to-Lead Ohms Readings (lockout/tagout power supply to pump controller).

Date completed:

Model Number	Lead-to-Lead Resistance (including Power Cable)		
	White/Gray - Black	Brown/Red - Black	Brown/Red - White/Gray
DEF-PMA150A	1.7 - 2.5 Ohms	4.6 - 5.4 Ohms	6.3 - 7.1 Ohms
DEF-PMA150D	2.9 - 3.7 Ohms	2.9 - 3.7 Ohms	2.9 - 3.7 Ohms

NOTE: Size and length of DEF STP wiring can affect ohms readings at the DEF Pump Control Box. If ohms readings do not seem correct, readings can be confirmed on the DEF PMA wire lead in the DEF STP Sump.

YES N/A

Verify DEF PMA Leads do not have continuity to Ground by checking each lead to green wire and/or earth ground. If continuity is found at pump controller, repeat testing on the DEF PMA power cord in the DEF STP sump to isolate issue.

Date completed:

6. Verify Configuration of DEF STP

YES N/A

Verify position of non-return check valve.

Date completed:

Verify position of bypass relief valve.

Date completed:

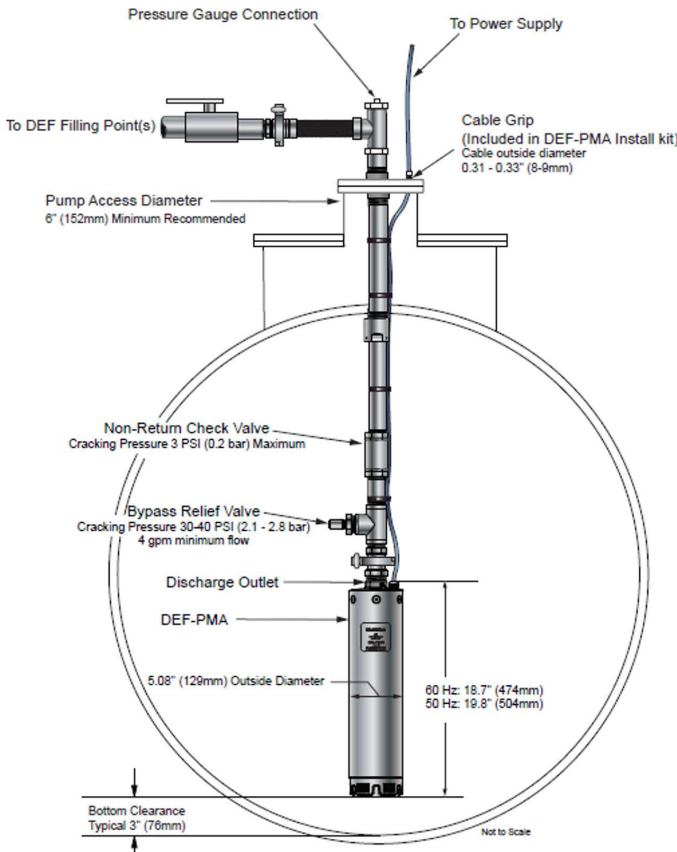

403395001 DEF-PMA Replacement Guide.pdf

YES N/A

Verify PMA markings (white and engraving match application).

Date completed:



YES N/A

Review condition of DEF PMA power cord.

Date completed:

Ripped, torn or partially removed from the DEF PMA.

Date completed:

Note any debris and/or contamination on DEF STP.

Date completed:

Measure DEF STP length to confirm bottom clearance (typically 3").

Date completed:

Compare DEF product level with bottom clearance.

Date completed:

NOTE: Recommend about 24" of DEF to prime new DEF PMA.

NOTE: If less than 24", consider adding Breather Hole to Bypass Relief Valve Bushing to accelerate priming.

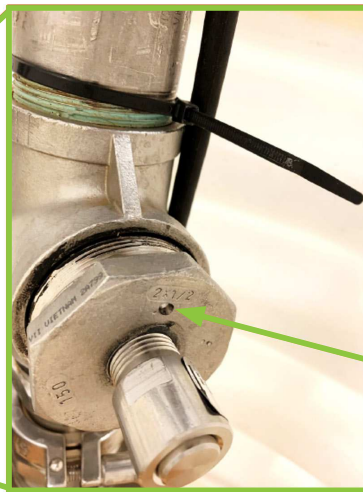
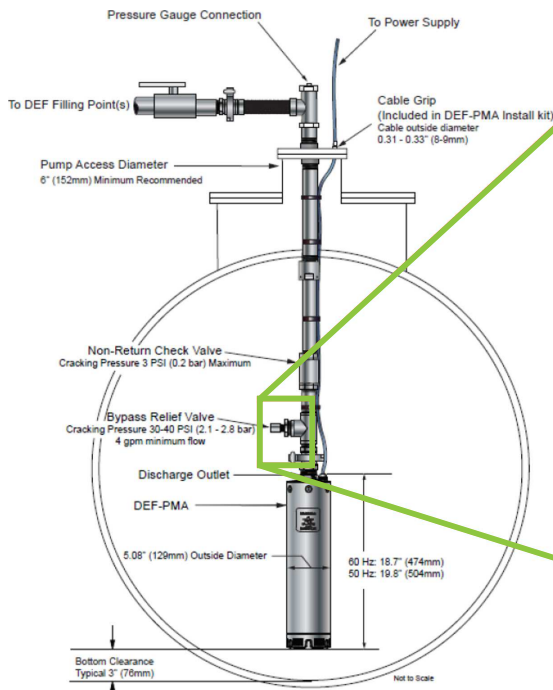

1/8" diameter Breather Hole Drilled through 2" x 1/2" Bushing adjacent to Bypass relief Valve to overcome possible crystallization lockup with low DEF levels in the storage tank.

7. Confirm motor spins freely – NOT LOCKED YES N/A

Verify position of non-return check valve.

Date completed:

Notes:

- End Cap is removable using flathead screwdriver light tap with hammer or mallet.
- Use 5/32 Allen wrench to test rotor is moving freely.
- Inspect for dents or damage to shell.
- Rotor is hard to turn – large amounts of play- replace.



Please submit with this form any pictures pertaining to:

Verification of Bypass Relief Valve and Non-Return Check Valve installation.

Existing conditions of the installation:

- Water in DEF Sump
- Water in DEF junction box
- Condition of DEF PMA
 - Dented/damaged PMA shell
 - Debris in or around PMA intake
 - Signs of crystallization

List serial number of existing DEF PMA if removed/replaced:

Serial number of replacement DEF PMA installed:

For Technical Assistance, or to acquire a Return Material Authorization number contact Franklin Fueling Systems Technical Support at 1-800-984-9904. Calls to the Technical Service Desk will receive a Call-In Ticket Number.

Return Material Authorization request will require:

- Distributor/Contractor Contact Information
- Serial number of DEF PMA to be returned
- Description of Defect
- This Service Form

FFS Technical Support Call-In Ticket Number:

60 Hz Wiring Diagrams

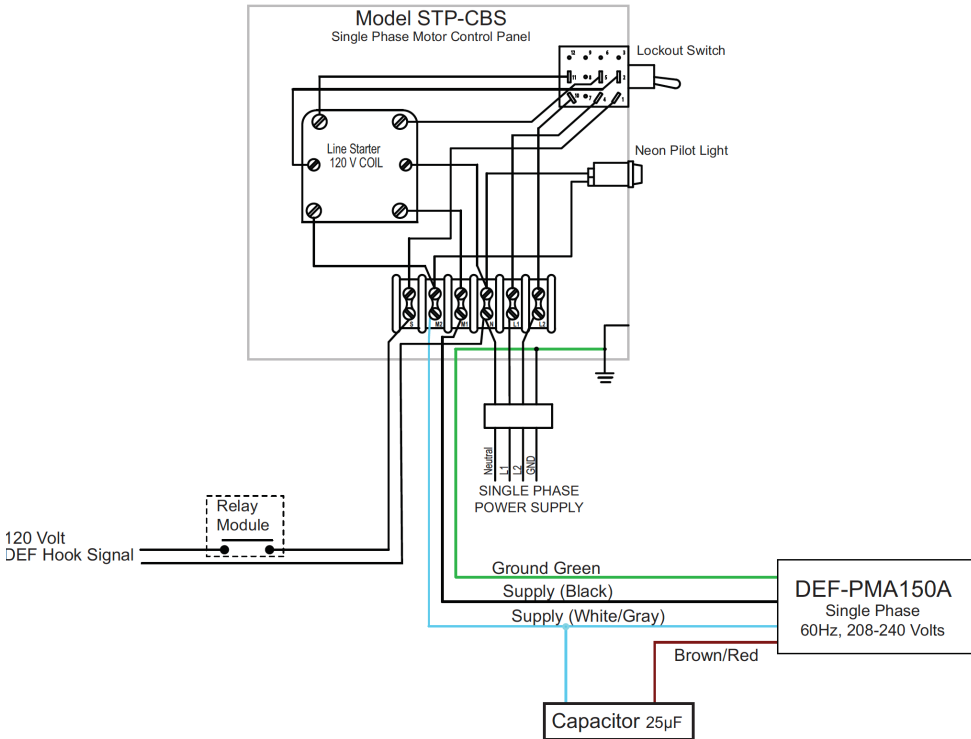

Figure 2: DEF-PMA150A Single-Phase Wiring

NOTE: The lockout switch is not a substitute for properly locking out and tagging out the electrical circuit when you service this equipment.

NOTE: You can install the single-phase DEF PMA capacitor near the motor control panel or in the tank sump. Make sure it is in a suitable enclosure to meet applicable codes.

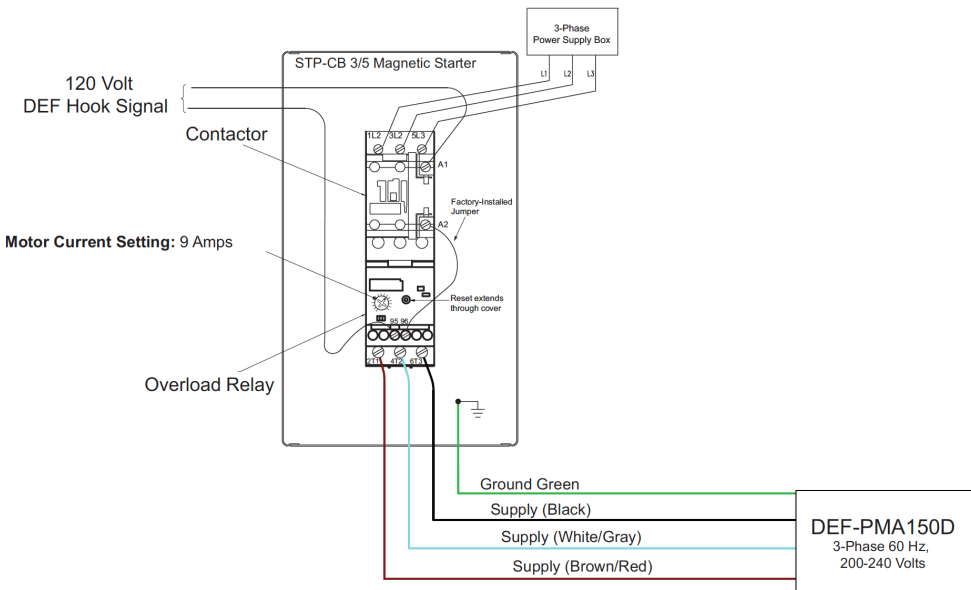

Figure 3: DEF-PMA150D Three-Phase Wiring

50 Hz Wiring Diagrams

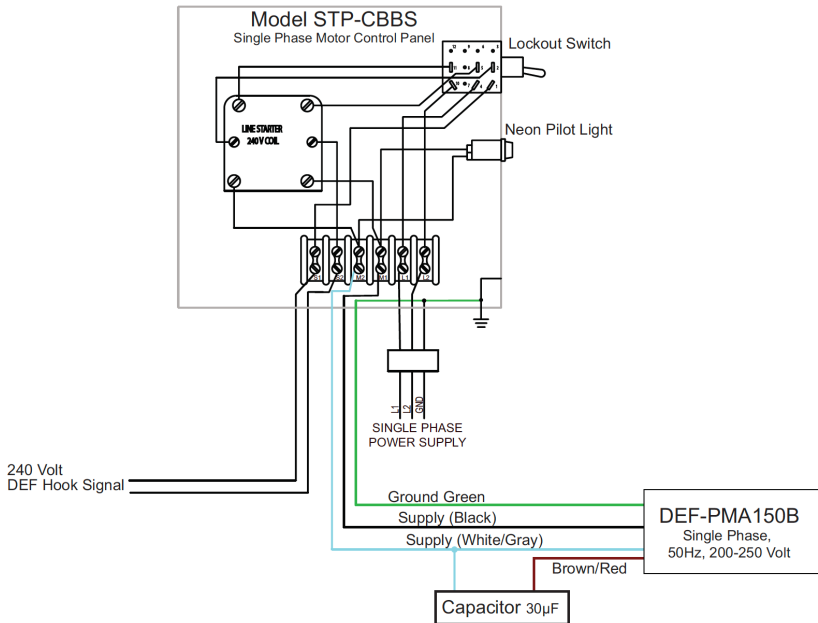

Figure 4: DEF-PMA150B Single-Phase wiring

NOTE: The lockout switch is not a substitute for properly locking out and tagging out the electrical circuit when you service this equipment.

NOTE: You can install the single-phase DEF PMA capacitor near the motor control panel or in the tank sump. Make sure it is in a suitable enclosure to meet applicable codes.

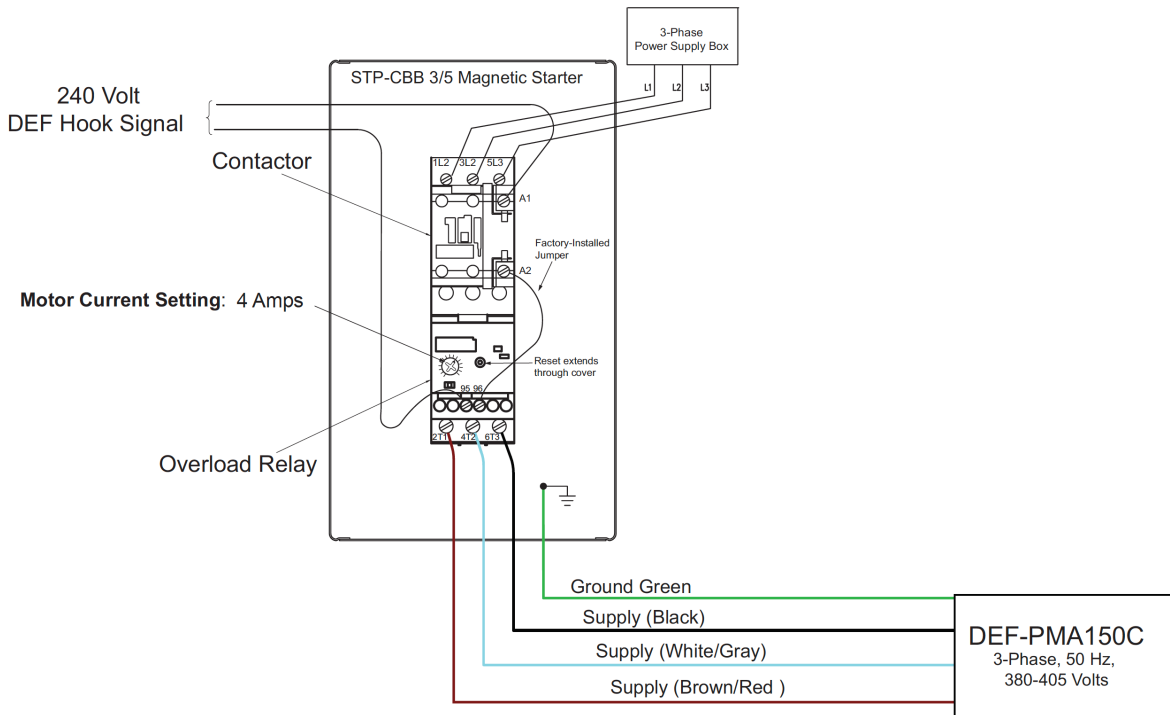

Figure 5: DEF-PMA150C Three-Phase Wiring

